

OWNER'S MANUAL AND INSTALLATION
INSTRUCTION FOR:

The PIONEER
P-15 and P-50

Natural Mineral Purification Systems



NATURAL MINERAL SANITATION
FOR POOLS AND SPAS

IMPORTANT SAFEGUARDS

WHEN INSTALLING AND USING THIS ELECTRICAL APPLIANCE, BASIC SAFETY PRECAUTIONS MUST ALWAYS BE ADHERED TO. IT IS STRONGLY ADVISED THAT A QUALIFIED ELECTRICAL TECHNICIAN PERFORM THE INSTALLATION OF THIS DEVICE.

WARNING

READ AND FOLLOW ALL INSTRUCTIONS CONTAINED IN THIS MANUAL AND ON THE EQUIPMENT ITSELF.

TO REDUCE THE RISK OF INJURY, DO NOT PERMIT CHILDREN TO USE THE APPLIANCE UNLESS THEY ARE CLOSELY SUPERVISED AT ALL TIMES.

WARNING...RISK OF ELECTRICAL SHOCK. CONNECT ONLY TO A GROUNDING TYPE RECEPTACLE PROTECTED BY A GROUND-FAULT CIRCUIT INTERRUPTER (GFCI) OR A DEDICATED CIRCUIT. CONTACT A CERTIFIED ELECTRICIAN IF YOU CANNOT VERIFY THAT THE RECEPTACLE IS PROTECTED BY AGFCI.

DO NOT BURY CORD. LOCATE CORD TO MINIMIZE ABUSE FROM LAWN MOWERS, HEDGE TRIMMERS AND OTHER EQUIPMENT. REPLACE ANY DAMAGED ELECTRICAL CORD IMMEDIATELY.

SHOULD THIS APPLIANCE BECOME INOPERATIVE, DO NOT TRY TO CORRECT THE PROBLEM BY YOURSELF. THERE ARE NO USER-SERVICEABLE PARTS INSIDE. TURN OFF, UNPLUG THE POWER CORD, AND CONTACT YOUR DEALER.

Pioneer H2O Technologies, Inc.
3265 South Wadsworth Blvd. Unit I
Lakewood, Colorado 80227 USA

Dear Valued Customer;

The Pioneer Natural Mineral Purification System is a complete water management program for your pool or spa. The P-15 or P-50 system safely and gently purifies your pool or spa while you enjoy water that is sparkling clear, safe and gentle on your hair, skin, and eyes.

Utilizing digital technology, the Natural Mineral Purification Systems micro-computer provides a constant mineral (Copper) sanitizer which devastates bacteria, yeast, mold, and all forms of algae. The result.....safe, sparkling, clear, pool water that will not harm your family or the environment.

We at Pioneer H2O Technologies know that you will immediately notice a dramatic difference in the quality of your pool's water. It is our hope that you will share this cutting edge technology with all of your friends.

Again, we compliment you on your wise decision to provide your family a healthier pool environment. We know you will enjoy the many benefits of the Natural Mineral Purification System for years to come.

Best Regards,

Pioneer H2O Technologies

TABLE OF CONTENTS

SYSTEM SPECIFICATIONS.....	5
MINERAL PURIFICATION TECHNOLOGY.....	6
P-15 & P-50 INSTALLATION.....	7
PLUMBING AND PLACEMENT.....	8
ELECTRICAL CONNECTIONS.....	9
WATER CHEMISTRY PRIOR TO START UP.....	10
PROPER POOL WATER CHEMISTRY.....	11
TOTAL ALKALINITY.....	12
CALCIUM HARDNESS.....	12
TOTAL DISSOLVED SOLID.....	12
COPPER.....	13
START-UP INSTRUCTIONS.....	14
WEEKLY MAINTENANCE.....	15
GENERAL MAINTENANCE.....	16
TROUBLESHOOTING GUIDE.....	17
WARRANTY	19
MAINTENANCE SCHEDULE.....	20
WARRANTY REGISTRATION.....	21

SYSTEM SPECIFICATIONS

CAPACITY:	P-15 Up to 15,000 gal. P-50 Up to 50,000 gal. P-100 Up to 100,000 gal.
MEDIUM SOURCE:	High grade virgin Copper alloy
INPUT VOLTAGE:	120/240 VAC @ 50/60 Hz; switch able
OUTPUT CAPACITY:	P-15 9, VDC @ 1 A – load depend P-50/P-100, 7 VDC @ 4 A – load depend
OUTPUT EFFICIENCY:	95% efficient across output spectrum
OUTPUT MODE:	Regulated DC current at 100% of duty cycle; steady state – load depend
POWER CONSUMPTION:	P-15 9 W max – load depend P-50/P-100 28 W max – load depend
CIRCUIT PROTECTION:	Solid state transient; fused primary and secondary. Continual load sampling with current limiting.
CONTROLLER DIMENSIONS:	P-15 4.50 in. x 4.50 in x 2.0 in. P-50/100 7.17 in. x 7.09 in. x 4.33 in.
CONTROLLER HOUSING:	P-50 High impact polycarbonate
TEMPERATURE LIMITS:	32 F min. to 120 F max
CONTROL PROCESSOR:	Regulated DC current; power “On” indicator, diagnostic LED display
COMPLIANCE:	P-50/P-100 EPA EST. No. 69282-FL-1 ETL listed and approved

MINERAL PURIFICATION TECHNOLOGY

The Natural Mineral Purification System utilizes an advanced electrolytic process which emits small amounts of Copper ions into water systems for the purpose of controlling micro-organisms and algae while avoiding the hazards of high level chemical dosing. From the backyard pool to the process cooling tower, the Natural Mineral Purification System can help save 60-90% on overall water treatment chemical expenditures. The system has a wide range of applications including food processing, marine parks, decorative fountains, cooling towers, breweries, and grey water treatment.

This method of water treatment is environmentally safe, user friendly and cost effective.

The system operates automatically in conjunction with the circulation system of a pool, spa, or cooling tower. A flow cell houses specially formulated virgin Copper alloy electrodes that deplete at a designated rate into the water that is to be treated. A long term disinfecting residual is then maintained by the system which is not depleted by heat or sunlight. Unlike chlorine, Copper does not degrade rapidly under those conditions. The electrode emissions created by the Natural Mineral Purification process are surface active, micro-biocidal and a potent algaecide. The disinfecting action is attributable to the positive charged Copper ions which form electrostatic bonds with negatively charged sites on the cell wall of micro organisms.

RESIDUAL SANITIZER

It has been field and laboratory proven that when mineral purification is used in conjunction with low levels of free chlorine, typically .2-.4 ppm (local health department regulations may vary); there is a synergistic effect (Applied and Environmental Microbiology, Dec. 1989, p. 3045-3050). The maximum synergistic effect was Copper in the presence of .3 ppm free available chlorine. At this dose, 1,000 times more bacteria were killed after 2.5 minutes in the ionized water than the water treated with chlorine alone.

P-15 & P-50 INSTALLATION

1. Disconnect all power to the pool system. DANGER: Risk of electrical shock. This step should be performed by qualified personnel. Locate a space for the Electrode Chamber - **after** the filter on the return line back to the pool.
2. Turn off the pump and close all the valves.
3. Using a hack saw, cut a 3-4 inch gap in the PVC pipe. Sand any burrs off of the pipe.
4. Dry the pipe and clean then ends with PVC primer/cleaner. Use supplied Reducer Bushings for installation of the Electrode Chamber into the 1 ½ in. pipe. Be sure to push the Reducer Bushing all the way into the Tee. Apply pressure for 30 seconds until the cement sets.
5. **For the P-15 model**, the Tee should be installed so that the Electrode cell is either perpendicular or parallel to the ground. Do not point the Electrode cell downward as air pockets will cause uneven Electrode wear and decreased performance. Any installation orientation on a vertical pipe will be correct.

For the P-50 and P-100 model, the Tee must be installed at a 5 degree offset from horizontal to avoid trapping debris and to prevent air pocket formation.

6. Swab PVC glue on the inside of the Tee and the ends of the pipe. After installing the Tee, be sure to hold firmly in place for 30 seconds before releasing.
7. Wrap Teflon tape around the treads on the Electrode cap prior to screwing it into the Electrode cell. **For the P-15**, screw in the Electrode cell so that water will pass between the two bars. For the **P-50 and P-100**, align the visible connections on the Electrode housing in parallel with the flow of water.
8. Secure the Electrode connections with the supplied nut and torque to “finger tight”.
WARNING: Torque exceeding finger tight may break the water seal as well as damaging the connector.

PLUMBING AND PLACEMENT

P-50

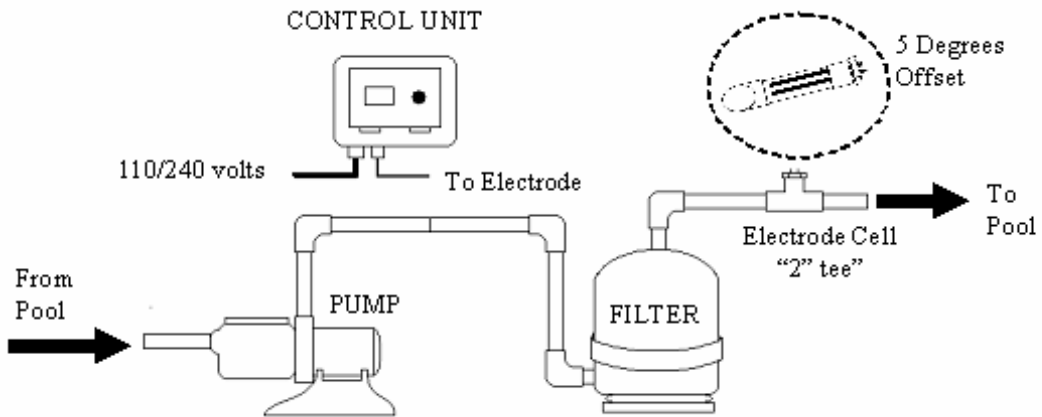

P-15

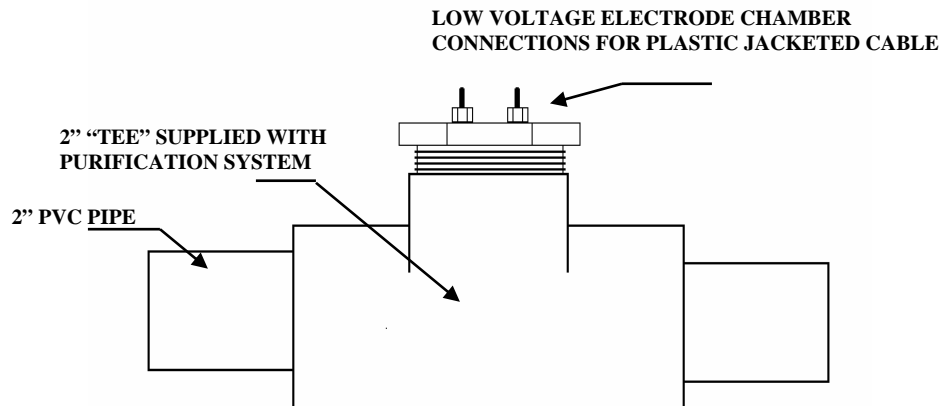

ELECTRICAL

CAUTION: INSTALLATION SHOULD BE DONE BY A QUALIFIED SERVICE PERSON IN ACCORDANCE WITH ALL APPLICABLE NATIONAL, STATE AND LOCAL ELECTRICAL STANDARDS AND BUILDING CODE REQUIREMENTS. CONSULT YOUR LOCAL AUTHORIZED DEALER FOR INSTALLATION SERVICES. DISCONNECT ALL POWER TO THE POOL CIRCULATION SYSTEM PRIOR TO INSTALLATION.

1. Determine input voltage; 120 VAC or 240 VAC. Set switch, locate on back of printed Circuit Board, to proper input voltage position. ALL SYSTEMS ARE PRESET TO 240 VAC
CAUTION: Improper voltage will damage the Controller.
2. Securely mount the Controller to a vertical surface in accordance with important safeguard and precautions. Make sure there is sufficient cable to accommodate wire connections between the Controller, the Electrode Chamber and the Power Source.
3. **WARNING:** CONTROLLER MUST OPERATE ONLY WHILE THE CIRCULATION SYSTEM IS RUNNING.
4. Use liquid tight flexible conduit between the Power Source and the Controller.
5. Use plastic jacketed conductors between the Electrode Chamber and the Controller.

WATER CHEMISTRY LEVELS PRIOR TO START-UP

****ATTENTION INSTALLER****

PRIOR TO THE INSTALLATION OF THE NATURAL MINERAL PURIFICATION SYSTEM, IT IS ESSENTIAL THAT THE FOLLOWING WATER CHEMISTRY PARAMETERS HAVE BEEN ESTABLISHED.

TOTAL DISSOLVED SOLIDS (TDS)

IDEAL RANGE 750-1,500 PPM

IF TDS IS BELOW 750 PPM, RAISE BY ADDING CRUSHED ROCK SALT. REFER TO FOLLOWING FORMULA: 10 LBS. OF SALT WILL RAISE TDS 120 PPM PER 10,000 GALLONS OF WATER. IF TDS IS ABOVE 1,500 PPM, PARTIALLY DRAIN POOL (BY AT LEAST 1/3) AND REFILL WITH FRESH WATER

pH (HYDROGEN POWER)

IDEAL RANGE: 7.2 – 7.6

CYANURIC ACID (STABILIZER)

IDEAL RANGE: 0 – 30 PPM

HALOGEN

IDEAL RANGE: .4 PPM CHLORINE - .8 PPM BROMINE

**STATE, LOCAL OR PROVINCIAL HEALTH CODES MAY VARY*

TOTAL ALKALINITY

IDEAL RANGE: 80 – 120 PPM

CALCIUM HARDNESS

IDEAL RANGE: 225 – 375 PPM

PROPER POOL WATER CHEMISTRY

pH

Ideal Range 7.2 – 7.6

pH stands for hydrogen power. This test determines the acid content of your pool water. As the pH rises above 7.6 there is a reduction in the Natural Mineral System's ability to purify. This test should be done weekly and adjusted accordingly.

If pH is above 7.6.....lower through use of muriatic acid or sodium bisulfate

If pH is below 7.2.....raise by using a base baking soda or soda ash

COMPLICATIONS WHICH MAY OCCUR FROM HIGH pH:

- Inability for sanitizer to kill algae and bacteria
- Solids may come out of solution
- Water may get cloudy
- Calcium may come out of solution and cause scale
- Eye irritation

COMPLICATIONS WHICH MAY OCCUR FROM LOW pH:

- Water becomes acidic
- Damage to pool and pool equipment
- Eye irritation

*RAIN OR ADDITION OF FRESH WATER WILL
CAUSE A CHANGE IN pH*

TOTAL ALKALINITY

Ideal Range 80 – 120 PPM

Total Alkalinity is a test done monthly to determine the amount of alkaline material in the water. It also measures the water's ability to neutralize acid and acts as a buffer against sudden pH changes.

If Total Alkalinity is high.....add small amounts of sodium bisulfate or muriatic acid over period of 3 days. Follow the label instructions based on your pool size.

If Total Alkalinity is low.....add bicarbonate (baking soda) ½ cup at a time, until you reach at least 80 PPM

CALCIUM HARDNESS

Ideal Range 225 – 375 PPM

Calcium Hardness is a test done yearly to determine the total amount of Calcium that's in the solution in the pool water. If the level is too high it can lead to scale, Calcium deposits, cloudy water and difficulty in controlling pH. If the level is too low it can lead to surface damage to the pool and fluctuating pH.

*If Calcium is too high....partially drain the pool and refill with fresh water
If Calcium is too low.....add calcium chloride following label directions*

TOTAL DISSOLVED SOLIDS

Ideal Range 750 – 1,500 PPM

*If TDS is too high.....partially drain pool by at least 1/3 and refill with fresh water
If TDS is too low.....raise by adding crushed rock salt.*

COPPER

Ideal Range .3 PPM

Copper, the primary purifying agent, attacks bacteria, virus, fungus, yeast, mold and all forms of algae. The range for Copper to effectively purify is .25 ppm in the winter when demand on the pool is minimal to a maximum of .4 ppm in the summer when demand is the greatest. The Copper should be tested weekly to both determine that the Copper is within recommended ranges and to determine what setting on the control box will tend to maintain Copper at a .3 ppm level; the ideal range.

After testing, if the Copper level is higher than .4 ppm, turn off the control box until the Copper falls back into the recommended range. Then turn the controller back on at a lower setting than previously. This could take up to several weeks as the Copper is only removed slowly by the pool filtration system. The Copper level is unaffected by UV or bather load. If the Copper level is too low, simply increase the setting on the controller. Follow guidelines to avoid algae growth and the possibility of the Copper precipitating and staining the pool. Although staining is rare, the possibility exists.

Maintaining proper Copper level is the responsibility of the operator. Pioneer H2O Technologies will not be held responsible if staining occurs. Visual inspection by the operator is required. If the staining appears, lower Copper levels below the recommended range.

START-UP INSTRUCTIONS

Step 1. After installation, clean the filter and check and adjust the water chemistry.

Step 2.

For the P-15 model – the dial will be set in the OFF position – turn the dial to the “10” position. Make sure the light comes on and changes from red/orange to green.

While the Copper is building, maintain a normal chlorine level. Run the system on the “10” setting until the Copper reaches .3 ppm. Depending on your pool size – this process may take between 1 and 3 days.

Reduce the controller setting to “5” and test the Copper level weekly to determine the optimum setting.

Each number changes is a 10% increase or decrease in the amount of Copper dispensed into the water.

The Power Polarity light will only be on when the filtration pump is running and the unit is creating Copper.

For the P-50 model – the dial will be set in the max INCREASE position. Make sure the LED display reads “10”.

The LED will display a number that decreases downwards from 10-1 as the knob is turned counter clockwise.

While the Copper is building, maintain a normal chlorine level. Run the system on the “10” setting until the Copper reaches .3 ppm. Depending on your pool size – this process may take between 1 and 3 days.

Reduce the controller setting to “5” and test the Copper level weekly to determine the optimum setting.

Each number changes is a 10% increase or decrease in the amount of Copper dispensed into the water.

The LED Display will only be on when the filtration pump is running and the unit is creating Copper.

On the left side of the # display you will see a + or a – sign indicating polarity reversal of the Electrodes. This occurs approximately every four minutes.

Step 3. Adjust circulation so the entire gallonage of the pool circulates through the filter at least 1½ times daily. Typically, a 1hp pump will circulate 3,000 gallons per hour.

WEEKLY MAINTENANCE

- Check and adjust your water chemistry. Proper pH is critical to effective purification
- Maintain chlorine at .4 ppm or bromine at .8 ppm
- Test Copper level and adjust as necessary

Please refer to tracking chart in the back of this manual. Be sure to keep accurate records regarding your pool's water chemistry. With these records your dealer can work quickly to answer any questions that may arise.

OXIDATION

The Pioneer Natural Mineral Purification System will flocculate dead organisms into larger masses, the majority of which will be removed by an efficient filtration system. However, organic matter such as suntan lotions, body oils, perspiration and hair care products will not be trapped by your filter. Although they pose no health hazard, left unattended, they will cause your pool to become cloudy or dull in appearance. Regular and sufficient oxidation is necessary to keep your pool water sparkling clear.

Proper oxidation can be accomplished in several ways, all of which are effective:

- Maintain a constant Chlorine residual of .4 ppm or Bromine at .8 ppm
- Add 1 quart of liquid bleach per 10,000 gallons on a weekly basis
- Add 1 pound of a non-chlorine (such as potassium monopersulfate) per 10,000 gallons on a weekly basis. This product is available in most pool stores.

Pioneer H2O Technologies recommends oxidizing once a week regardless, and always after a heavy, sustained rain. *Oxidizing is an essential element for the effective operation of you Natural Mineral Purification System.

GENERAL MAINTENANCE

ELECTRODES

The Electrodes are uniquely designed so they will not restrict the flow of water in your plumbing. The life of your Electrode will vary depending on the size of your pool and the number of hours the filtration system runs each day.

P-15 model – Remove Electrodes periodically for inspection and cleaning.

P-50 model –

When the Electrodes need to be cleaned or the Total Dissolved Solids levels gets too high, one decimal point will flash or blink at the top left side of the LED display.

Electrodes should be inspected through the clear plastic Tee periodically to ensure there is nothing obstructing flow or caught between them. Electrodes should be checked a minimum of once per year whether the decimal points flash or not.

If the cleaning of Electrodes becomes necessary, turn off the power to the system, disconnect fitting and remove the Electrode. To clean – use a 50:50 solution of vinegar or lemon juice and water. Rinse with a garden hose.

CAUTION: MAKE SURE THE POWER IS OFF AND THE FILTRATION SYSTEM IS NOT RUNNING BEFORE ATTEMPTING TO CLEAN THE ELECTRODES

You can obtain new Electrodes through your local dealer

TROUBLESHOOTING GUIDE

If you have followed the instructions contained in your Natural Mineral Purification System manual and are still having difficulty operating your system, locate the SYMPTOM in the left column below. Check the corresponding POSSIBLE CAUSE and CORRECTIVE ACTION columns to remedy the problem.

SYMPTOM	POSSIBLE CAUSE	CORRECTIVE ACTION
LED not lit	Blown fuse from power surge Power cord wired incorrectly Power cord wires not secure Control knob is in the off position	Remove control panel and replace ½ amp fuse Refer to wiring diagram/installation Observe wire connections and secure Turn knob until number 10 appears
LED displays only + or - or decimal points flashing	120/240 VAC switch in wrong position TDS is too high Debris coating Electrodes Electrodes need to be replaced	Confirm incoming voltage and adjust switch Check TDS. Partially drain pool and refill Clean and reinstall Electrodes Call your dealer to order new Electrodes
No voltage to the Electrodes	Unit in off position 120/240 switch in wrong position Wires not secure	Turn the control box on Check incoming voltage and adjust switch Check all connections and secure
Copper level low	Electrodes need to be cleaned Electrodes need to be replaced TDS is too low	Clean Electrodes with vinegar Call your dealer to order new Electrodes Check TDS level and add rock salt
Algae in pool or brown/cloudy water	pH too high or TDS is too low	Review owners manual for water chemistry and maintenance procedures
Water is cloudy	Filter is dirty	Backwash filter, clean filter, add Oxidizer with bleach or non-chlorine shock

ADJUSTING pH TO 7.2 WITH SODIUM BISULFATE (DRY ACID)

pH READING	500 GAL	5,000 GAL	10,000 GAL	15,000 GAL
7.8 – 8.0	1 OZ	.75 LBS	1.25 LBS	2.5 CUPS
8.0 – 8.2	1.5 OZ	1 LB	2 LB	3.75 CUPS
8.4 +	2.0 OZ	1.5 LBS	2.5 LBS	5.0 CUPS

ADJUSTING pH TO 7.2 WITH MURIATIC ACID

pH READING	500 GAL	5,000 GAL	10,000 GAL	15,000 GAL
7.8 – 8.0	4 TSP	.75 CUPS	13 OZ	2.5 CUPS
8.0 – 8.2	2 TSP	1.25 CUPS	2.5 CUPS	3.75 CUPS
8.4 +	3 TSP	1.5 CUPS	3.5 CUPS	5.0 CUPS

THESE DOSAGE AMOUNTS MAY VARY SLIGHTLY FOR YOUR POOL AS ALL WATER CHEMISTRIES DIFFER. INITIALLY, BEGIN WITH THE ABOVE LEVELS AS A GUIDELINE. AFTER APPLICATION, CHECK YOUR pH AGAIN IN 2 HOURS. MAKE ANY NECESSARY ADJUSTMENTS AND NOTE FOR FUTURE APPLICATIONS.

LIMITED WARRANTY

PIONEER H2O TECHNOLOGIES

Believing The Natural Mineral Purification System

To be of exceptional quality, hereby warranties said equipment to the original purchaser only against defective parts and workmanship for a period as stated:

P-15 1 Year Warranty – Controller

P-50 1 Year Warranty – Electronic Controller

This warranty begins at the time the equipment is installed and is contingent upon the return of signed owner registration card to the manufacturer.

This warranty does not require replacement of the entire unit. Manufacturer will repair or replace (at its option) any part that proves to be defective in material and/or workmanship during the warranty period under normal use and service. If the equipment does not perform properly, refer to your owners manual and water chemistry before requesting service from the dealer that sold you the system.

This warranty does not cover labor charges and does not cover installation, removal, reinstallation, transportation, or any other claims or torts including but not limited to damage caused by abuse, neglect, freezing, fire, lightening, staining, vandalism, failure to maintain proper water chemistry or other abnormal conditions beyond the company's control.

This warranty gives you specific legal rights and you may have other rights that vary from state to state or province to province. You also have implied warranty rights. This warranty is void if equipment is not installed and operated according to the owner's manual including, but not limited to, maintaining proper water chemistry level at installation and thereafter. Service provided by technicians other than

PIONEER H2O TECHNOLOGIES or other authorized agents may void this warranty.

MAINTENANCE SCHEDULE

TASK	DESCRIPTION	WHEN
CHECK COPPER	SUMMER .3-.4 PPM FALL/SPRING .3 PPM	WEEKLY
OXIDIZE	1 QT. BLEACH 10,000 GAL OR 1 LB. POTASSIUM MONOPERSULFATE	WEEKLY AND AFTER RAIN
CHECK pH	7.2 – 7.6	WEEKLY
ALKALINITY	80-120 PPM 100 PPM IDEAL	MONTHLY
CALCIUM	225-375 PPM	YEARLY
CLEAN FILTER	WHEN PRESSURE GAUGE IS 50-75% ABOVE NORMAL	AS NEEDED
CLEAN POOL	VACUUM DIRT, LEAVES, DEAD ALGAE CLEAN SKIMMER	AS NEEDED

NOTES:

WATER CHEMISTRY TRACKING CHART

RANGE: DATE	7.2 - 7.6 pH	80 - 120 PPM ALKALINITY	.2 - .4 PPM COPPER	.4 - .8 PPM HALOGEN	ACTION TAKEN

Pioneer H2O Technologies, Inc.

3265 South Wadsworth Blvd. Unit "I"
Lakewood, Colorado 80227 USA
1-877-569-4377

Warranty Registration Card

(Return Within 30 Days of Purchase)

Owners Name: _____

Street Address: _____

City: _____ State/Prov: _____ Zip/Postal: _____

Phone: _____

Date of Purchase: _____ Supplier: _____

Model # _____

Serial Number _____

